

◎ POWER RATING

Intermittent rating kW(PS) / rpm	Max. torque N.m(kg.m) / rpm	Fuel consumption g/kW.h(g/PS.h) / rpm
118 (160) / 2,200	588 (60) / 1,600	228 (168) / 2,200

1. The engine performance corresponds to ISO 3046.
2. Continuous power rating is to 107kW(145ps) @2200rpm.



◎ MECHANICAL SYSTEM

- Engine Model PU086
- Engine Type In-line 4 cycle, water cooled
Naturally aspirated
- Combustion type Direct injection
- Cylinder Type Replaceable dry liner
- Number of cylinders 6
- Bore x stroke 111(4.37) x 139(5.47) mm(in.)
- Displacement 8.071(492.49) lit.(in3)
- Compression ratio 16.8 : 1
- Firing order 1-5-3-6-2-4
- Injection timing 18° BTDC
- Compression pressure Above 28 kg/cm²(398 psi) at 200rpm
- Dry weight Approx. 780 kg (1,720 lb)
- Dimension 1,244 x 716 x 900 mm
(LxWxH) (48.2 x 28.2 x 35.5 in.)
- Rotation Counter clockwise viewed from Flywheel
- Fly wheel housing SAE NO.2M
- Fly wheel Clutch NO.11 1/2M

◎ MECHANISM

- Type Over head valve
- Number of valve Intake 1, exhaust 1 per cylinder
- Valve lashes at cold Intake 0.30 mm(0.0118 in)
Exhaust 0.30 mm(0.0118 in.)

◎ VALVE TIMING

- | | Opening | Close |
|-----------------|--------------|--------------|
| ○ Intake valve | 16 deg. BTDC | 36 deg. ABDC |
| ○ Exhaust valve | 46 deg. BBDC | 14 deg. ATDC |

◎ OPTION & ACCESSORY PARTS

- Engine parts Fly wheel & housing
Intake & exhaust manifold
- Accessory parts Raditor, silencer & air cleaner
- Electrical parts Gauge panel & stop solenoid

◎ FUEL SYSTEM

- Injection pump Zexel in-line "AD" type
- Governor RSV type(all speed control)
- Feed pump Mechanical type
- Injection nozzle Multi hole type
- Opening pressure 214 kg/cm² (3,044 psi)
- Fuel filter Full flow, cartridge type
- Used fuel Diesel fuel oil

◎ LUBRICATION SYSTEM

- Lub. Method Fully forced pressure feed type
- Oil pump Gear type driven by crankshaft
- Oil filter Full flow, cartridge type
- Oil pan capacity High level 15 liters (4.09 gal.)
Low level 12 liters (3.17 gal.)
- Angularity limit Front down 25 deg.
Front up 25 deg.
Side to side 25 deg.
- Lub. Oil Refer to Operation Manual

◎ PERFORMANCE CURVE

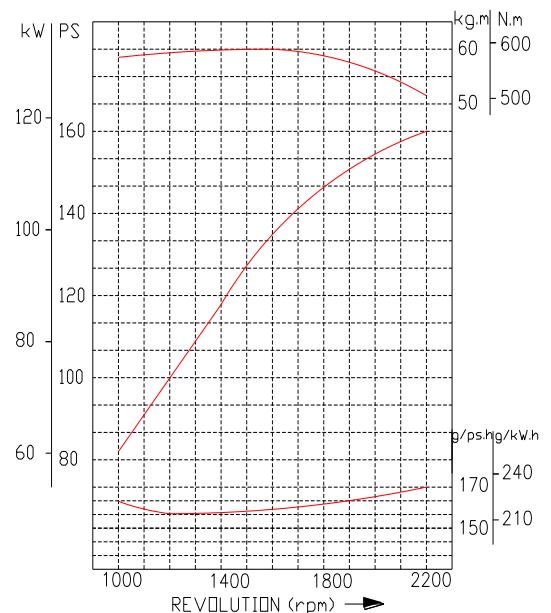

◎ COOLING SYSTEM

- Cooling method Fresh water forced circulation
- Water capacity 14 liters (3.70 gal.)
(engine only)
- Pressure system Max. 0.9 kg/cm² (12.8 psi)
- Water pump Centrifugal type driven by belt
- Water pump Capacity 190 liters (41.8 gal.)/min
at 2,200 rpm (engine)
- Thermostat Wax – pellet type
Opening temp. 71°C
Full open temp. 85°C
- Cooling fan Blower type, steel
590 mm diameter, 6 blade

◎ ELECTRICAL SYSTEM

- Charging generator 24V x 45A [or 12V x 26A] alternator
- Voltage regulator Built-in type IC regulator
- Starting motor 24V x 4.5kW [or 12V x 2.5kW]
- Battery Voltage 24V [or 12V]
- Battery Capacity 100 AH [or 150 AH](recommended)
- Starting aid (Option) Block heater

◎ ENGINEERING DATA

- Water flow 190 liters/min @2,200 rpm
- Heat rejection to coolant 20.2 kcal/sec @2,200 rpm
- Air flow 8.4 m³/min @2,200 rpm
- Exhaust gas flow 22.9 m³/min @2,200 rpm
- Exhaust gas temp. 480 °C @2,200 rpm
- Max. permissible restrictions
 - Intake system 220 mmH₂O initial
635 mmH₂O final
 - Exhaust system 1,000 mmH₂O max.

◆ CONVERSION TABLE

in. = mm x 0.0394	lb/ft = N.m x 0.737
PS = kW x 1.3596	U.S. gal = lit. x 0.264
psi = kg/cm ² x 14.2233	kW = 0.2388 kcal/s
in ³ = lit. x 61.02	lb/PS.h = g/kW.h x 0.00162
hp = PS x 0.98635	cfm = m ³ /min x 35.336
lb = kg x 2.20462	

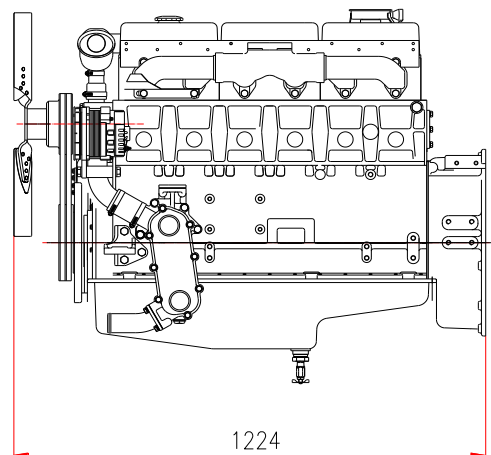
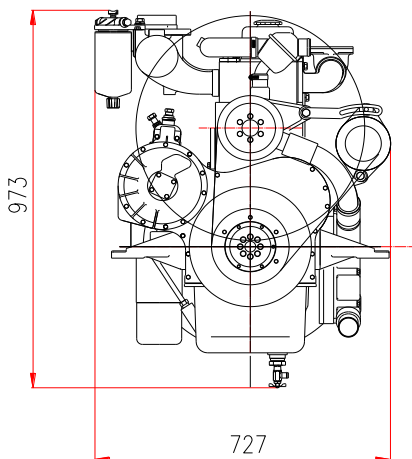

Doosan Infracore Co., Ltd.

21st Floor, Doosan Tower, 18-12, Euljiro 6-ga,
Jung-gu, Seoul, Korea

TEL : +82-2-3398-8400 / Fax : +82-2-3398-8509

E-mail : enginesales@doosan.com

Web site : www.doosaninfracore.com

※ Specifications are subject to change without prior notice