

SPECIFICATIONS

Thermodynamic Cycle	Diesel 4 stroke
Air Handling	TAA
Arrangement	6L
Bore x Stroke (mm)	135 X 150
Total Displacement (l)	12.88
Valves per cylinder (n°)	4
Cooling System	liquid
Direction of Rotation (viewed facing flywheel)	CCW
Compression ratio	16.5:1
Injection System	EUI

PERFORMANCE

Rated power [*] (kW (HP) @ rpm)	407 (554) @ 2100
Peak power (kW (HP) @ rpm)	414 (563) @ 1900
Peak torque (Nm (kgm) @ rpm)	2400 (245) @ 1400
High idle speed (rpm)	2280
Low idle speed (rpm)	± 850
DEF**]/AdBlue consumption at peak torque and rated power (% of fuel cons.)	7 - 8
Minimum starting temperature without auxiliaries (°C)	-15 °
Oil and oil filter maintenance interval for replacement [***] (hours)	600

STANDARD CONFIGURATION

Flywheel housing (type)	SAE 1 - aluminium
Flywheel size (inch)	14"
Intake manifold location	middle high / right side / front
Exhaust manifold location	middle high / left side / back
Turbocharger	fixed geometry with waste gate valve
Turbocharger location	center / left side
Fan transmission ratio	1.37:1
Distance between fan - crankshaft centers (mm)	X = -20 Y = 225
Fuel filter (n°)	single cartridge - right side
Fuel prefilter	-
Fuel Pump	-
Oil filter (n°)	single cartridge - left side
Oil sump	suspended sheet / front sump
Oil vapours blow-by circuit	close case ventilation
Oil heat exchanger	integrated into the block
Oil filler	on valve cover
Starter	24V - 5.5kW
Alternator	24V - 90A
Engine stop device	by electronic control unit
Wiring harness	interface wiring loom with accessories
Painting color	grey

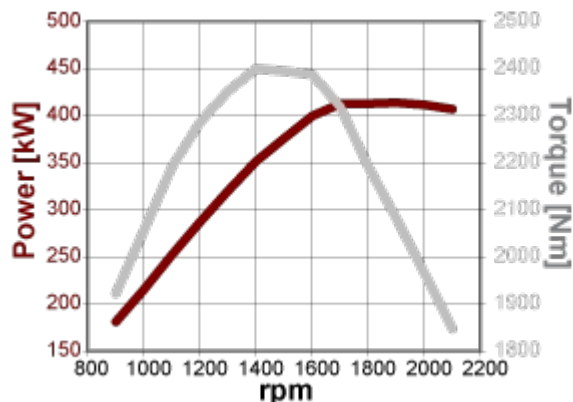

WEIGHT AND DIMENSIONS

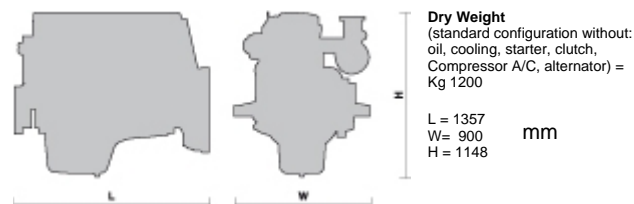

NOT INCLUDED IN STANDARD CONFIGURATION

Power Take Off (PTO)	-
PTO - transmission ratio	1.36:1
PTO - maximum available torque	SAE A 150Nm (9 teeth - ANSI B92,1) SAE B 150Nm (13 teeth ANSI B92,1) SAE B 200Nm (splined - DIN 5482)
Battery - minimum capacity recommended [*] (Ah)	180Ah (24V)
Battery - minimum cold cranking capacity recommended [*] (A)	800A (24V)

[*] Power at flywheel according to 97/68 EC (without fan), after 50 hours running, 3% tolerance.

[**] DEF: Diesel Exhaust Fluid.

[***] Oil type: Approved engine oil specification: 15W-40 ACEA E7 / API CI-4 or 10W-30 ACEA E7 / API CI-4.

Legend

Arrangement	Air Handling	Turbocharger	Injection System	Emission Standard	Exhaust System
L (in line)	TAA (Turbocharged with aftercooler) TC (Turbocharged) NA (Naturally Aspirated)	WG (Wastegate) VGT (Variable Geometry Turbocharger) TST (Twin Stage Turbocharge)	M (Mechanical): ECR (Electronic Common Rail) EUI (Electronic Unit Injector)	EEV (Enhanced Environmentally friendly Vehicle)	EGR (Exhaust Gas Recirculation) SCR (Selective Catalytic Reduction)

FOR INFORMATION ON THE AVAILABLE RATINGS NOT LISTED IN THIS DOCUMENT PLEASE CONTACT THE FPT INDUSTRIAL SALES NETWORK OR VISIT OUR SITE WWW.FPTINDUSTRIAL.COM



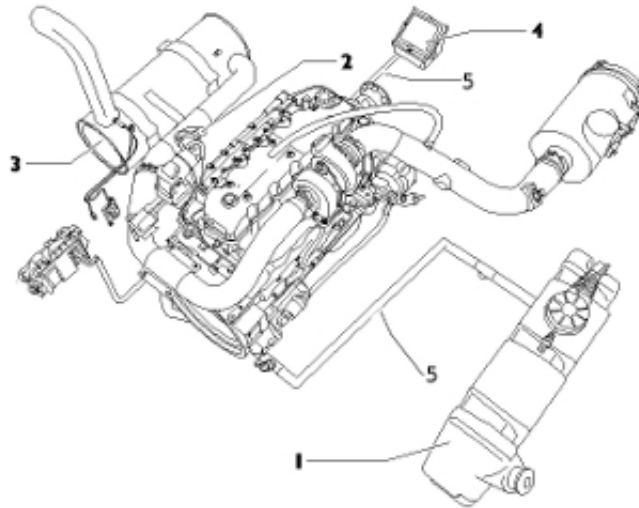

SCR (Selective Catalytic Reduction) system

Main components

- 1) AdBlue/DEF* Tank: available options 156 liters
- 2) Dosing Module
- 3) SCR muffler: available options Vertical configuration
- 4) Supply Module
- 5) AdBlue/DEF* pipes

*DEF: Diesel Exhaust Fluid

FPT INDUSTRIAL OFFERS THE WIDEST AVAILABILITY OF ENGINE BUILD OPTIONS TO CUSTOMER SPECIFIC REQUIREMENTS WITHIN THE ENGINE SUPPLY. TO FIND OUT MORE ABOUT THE CONFIGURATIONS AND ACCESSORIES WHICH ARE AVAILABLE

