

SPECIFICATIONS

Thermodynamic Cycle	Diesel 4 stroke
Air Handling	TAA
Arrangement	6L
Bore x Stroke (mm)	104 X 132
Total Displacement (l)	6.7
Valves per cylinder (n°)	4
Cooling System	liquid
Direction of Rotation (viewed facing flywheel)	CCW
Compression ratio	17:1
Injection System	ECR

PERFORMANCE

Rated power [*] (kW (HP) @ rpm)	181 (246) @ 2200
Peak power (kW (HP) @ rpm)	191 (260) @ 1800
Peak torque (Nm (kgm) @ rpm)	1120 (114) @ 1500
High idle speed (rpm)	2375
Low idle speed (rpm)	± 850
DEF[**]/AdBlue consumption at peak torque and rated power (% of fuel cons.)	-
Minimum starting temperature without auxiliaries (°C)	-15 °
Oil and oil filter maintenance interval for replacement [***] (hours)	600

STANDARD CONFIGURATION

Flywheel housing (type)	SAE 3 - cast iron
Flywheel size (inch)	11" ½
Intake manifold location	high / left side / vertical from top
Exhaust manifold location	high / right side / front
Turbocharger	fixed geometry with waste gate valve
Turbocharger location	high / back / right side
Fan transmission ratio	1.4:1
Distance between fan - crankshaft centers (mm)	X = 0 Y = 296
Fuel filter (n°)	single cartridge - left side
Fuel prefilter	-
Fuel Pump	-
Oil filter (n°)	single cartridge - right side
Oil sump	suspended sheet steel / front sump, 35° angularity limits continuous in all directions
Oil vapours blow-by circuit	flywheel housing, Mann & Hummel valve
Oil heat exchanger	integrated into the block
Oil filler	on valve cover
Starter	24V - 4kW
Alternator	24V - 70A with W contact
Engine stop device	incorporated in the pump
Wiring harness	-
Painting color	grey

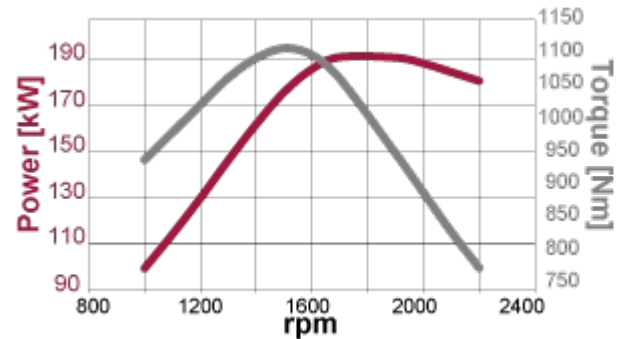

WEIGHT AND DIMENSIONS



Dry Weight
(standard configuration without:
oil, cooling, starter, clutch,
Compressor A/C, alternator) =
Kg 520

L = 1062 mm
W = 681 mm
H = 1018 mm

NOT INCLUDED IN STANDARD CONFIGURATION

Power Take Off (PTO)	-
PTO - transmission ratio	1.03:1
PTO - maximum available torque	SAE A 100Nm (9 teeth) - 150Nm (11 teeth) SAE B 240Nm (13 teeth)
Battery - minimum capacity recommended [*] (Ah)	130Ah (24V)
Battery - minimum cold cranking capacity recommended [*] (A)	500A (24V)

[*] Power at flywheel according to 97/68 EC (without fan), after 50 hours running, 3% tolerance.

[**] DEF: Diesel Exhaust Fluid.

[***] Oil type: Approved engine oil specification: 15W-40 ACEA E7 / API CI-4 or 10W-30 ACEA E7 / API CI-4.

Legend

Arrangement L (in line)	Air Handling TAA (Turbocharged with aftercooler) TC (Turbocharged) NA (Naturally Aspirated)	Turbocharger WG (Wastegate) VGT (Variable Geometry Turbocharger) TST (Twin Stage Turbocharge)	Injection System M (Mechanical): ECR (Electronic Common Rail) EUI (Electronic Unit Injector)	Emission Standard EEV (Enhanced Environmentally friendly Vehicle)	Exhaust System EGR (Exhaust Gas Recirculation) SCR (Selective Catalytic Reduction)
-----------------------------------	---	---	--	---	---

FOR INFORMATION ON THE AVAILABLE RATINGS NOT LISTED IN THIS DOCUMENT PLEASE CONTACT THE FPT INDUSTRIAL SALES NETWORK OR VISIT OUR SITE WWW.FPTINDUSTRIAL.COM



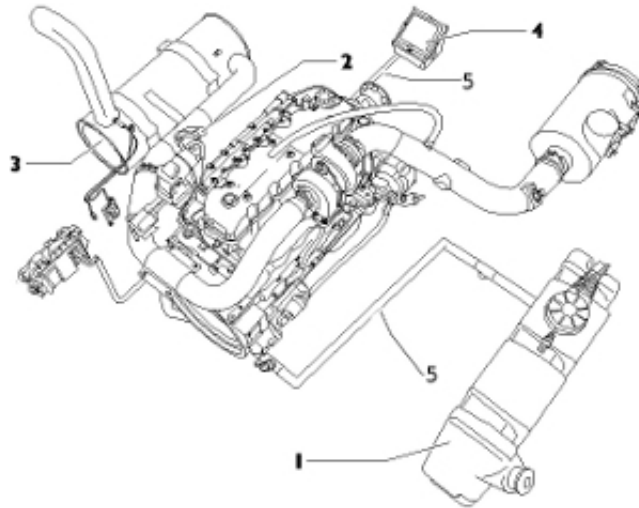

SCR (Selective Catalytic Reduction) system

Main components

- 1) AdBlue/DEF* Tank: available options 43 and 61 liters
- 2) Dosing Module
- 3) SCR muffler: available options Vertical and Horizontal configuration
- 4) Supply Module
- 5) AdBlue/DEF* pipes

*DEF: Diesel Exhaust Fluid

FPT INDUSTRIAL OFFERS THE WIDEST AVAILABILITY OF ENGINE BUILD OPTIONS TO CUSTOMER SPECIFIC REQUIREMENTS WITHIN THE ENGINE SUPPLY. TO FIND OUT MORE ABOUT THE CONFIGURATIONS AND ACCESSORIES WHICH ARE AVAILABLE

